

ES09E0RS
(ON DRAWING) 台架図

版数 REV.	年月日 DATE	DCN NO.	変更内容 DESCRIPTION	製図 DR.	担当 CHK.	査閲 APPD.	承認 APPD.
2	17.May.2002	49985	CORRECT THE SPECIFICATION NUMBER		A.MATSUNAGA	A.Natori	K.Suzuki

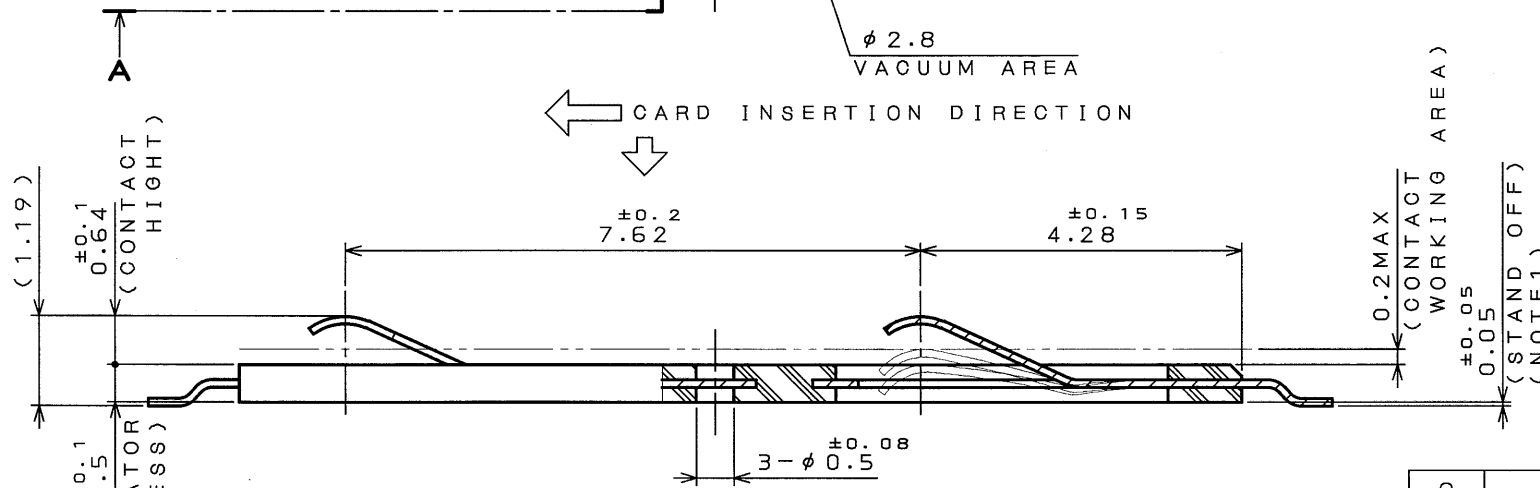

DOF-0-212D(98.02)

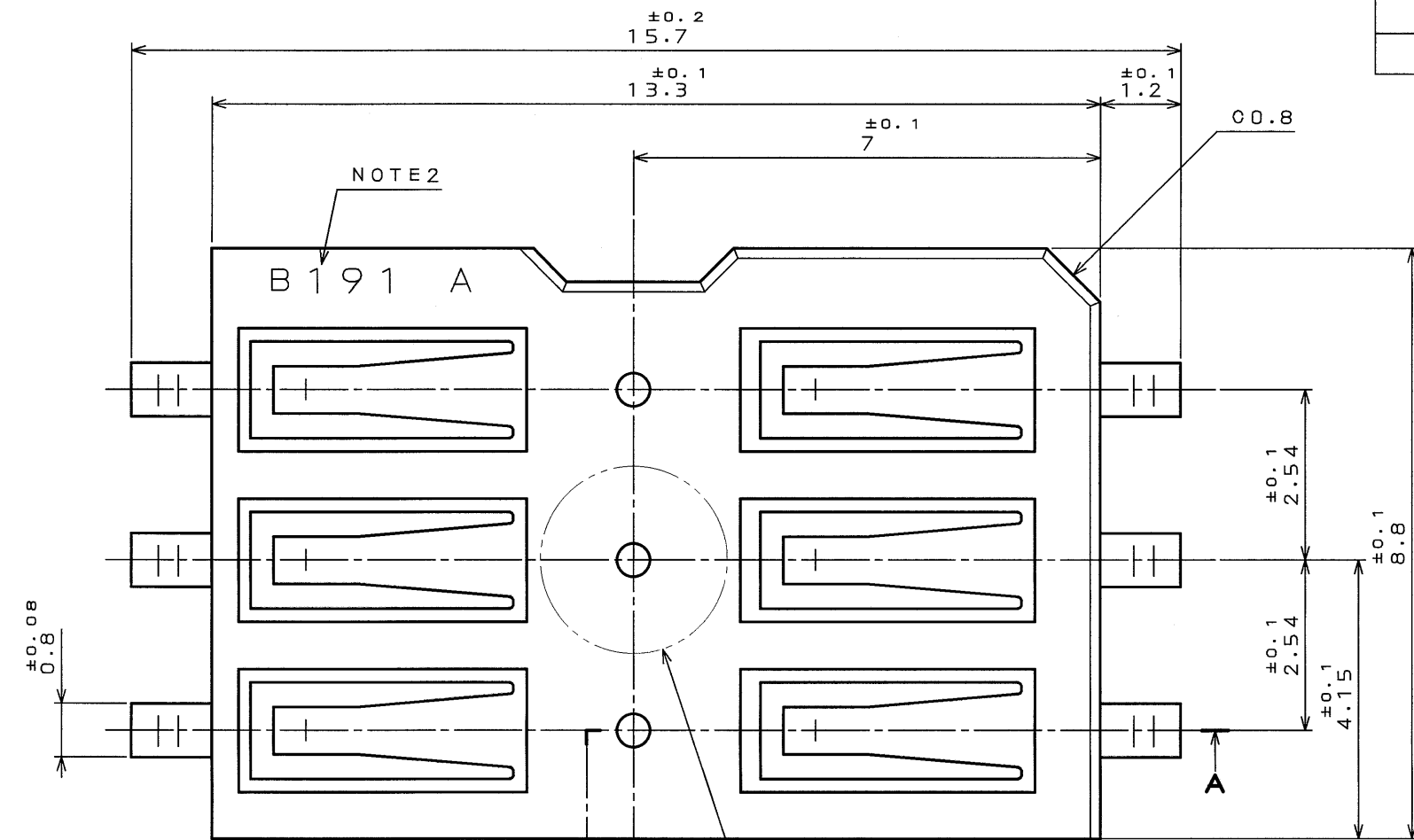
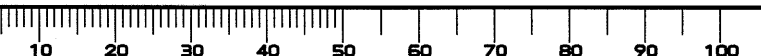

JAE Connector Div. Proprietary.
Copyright © Japan Aviation Electronics Industry, Ltd.

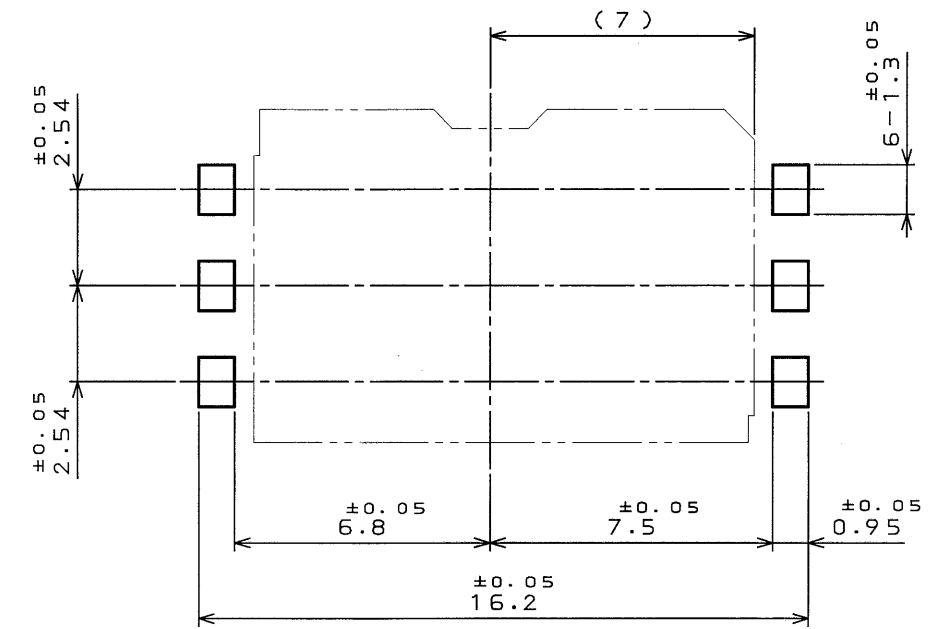

APPLICABLE P.C.B. DIMENSION (REF.)

NOTE 1. COPLANARITY SHOULD BE 0.1mm MAX.
NOTE 2. PRODUCTION LOT NUMBER AND CAVITY NUMBER AS INDICATED.

(EX) B 1 9 1 A
CAVITY NUMBER (A, B, ..., n)
LOT NUMBER OF CURRENT MONTH
MONTH (1 TO 9 FOR JAN. TO SEPT. RESPECTIVELY
OCT.: 0, NOV.: X, DEC.: Y)
YEAR (LAST DIGIT ONLY)
MANUFACTURE CODE

SECT. A-A

TABLE 1. CONTACT FINISH

CONTACT AREA	TERMINAL AREA
GOLD 0.5 μm MIN OVER NICKEL	GOLD 0.03~0.08 μm OVER NICKEL

2	INSULATOR	1	GLASS FILLED Ny	UL94 V-0 COLOR: BLACK	
1	CONTACT	6	COPPER ALLOY	TABLE 1	
符号 NO.	名称 DESCRIPTION	個数 QTY.	材 料 MATERIAL	仕上 FINISH	備考 REMARKS
仕様書 (SPECIFICATION)		第1版 (ORIGINAL DATE)		尺度 (SCALE)	
△ JACS-1556-7		2.Jul.2001		10:1 SF2	
公差 (GENERAL TOLERANCE)		製図 DR.		名称 (TITLE)	
寸法 (DIMENSION)		担当 CHK.		SF2W006S4K	
角度 (ANGLES)		査閲 APPD.		重量 (WEIGHT)	
. ±0.8		A.MATSUNAGA		⊕	
.X ±0.4		A.NATORI		⊖	
.XX ±0.1		承認 APPD.		K.SUZUKI	
.XXX ±					
				図面番号 (DRAWING NO.)	
				SJ036053	
				版数 (REV.)	
				2	

本図面は日本航空電子工業(株)の所有する情報を含むもので当社の許可なく複製を禁止する。
THIS DRAWING CONTAINS INFORMATION THAT IS PROPRIETARY TO JAE AND CAN NOT BE REPRODUCED WITHOUT WRITTEN CONSENT OF JAE.

CDS-01-170-10385
SIZE A3